

INSTALLATION INSTRUCTIONS - CRDA-4SS SERIES CRASH RAIL

GENERAL

1. ALL DECORATIVE ALUMINUM COVERS ARE SHIPPED IN STOCK LENGTHS OF 8'-0" TO BE CUT IN THE FIELD TO FIT.
2. CAREFULLY MEASURE AND MARK ALL HOLES TO BE DRILLED TO ACHIEVE A PROPERLY SUPPORTED AND LEVEL INSTALLATION.

GUIDELINES FOR INSTALLATION:

1. MEASURE AND MARK THE TOP OF THE CRASH RAIL AND RAIL SYSTEM CENTERLINE ON WALL OR PARTITION.
2. MEASURE AND MARK THE ENDPOINTS OF THE CRASH RAIL ON THE CENTERLINE.
3. MEASURE AND CUT RETAINER AND COVER SECTIONS TO LENGTH FOR EACH CRASH RAIL SEGMENT (OFFSETTING THE COVER JOINTS FROM THE WOOD RETAINER JOINTS IS RECOMMENDED FOR A MORE UNIFORM APPEARANCE). VERIFY THAT CUT LENGTHS CONFORM EXACTLY TO LENGTHS MARKED ON WALL OR PARTITION. IF THE RETAINER LENGTHS ARE LONGER THAN THE DECORATIVE ALUMINUM CRASH RAIL COVER LENGTHS, THE END PLATES WILL NOT PULL TIGHT AGAINST THE CRASH RAIL ENDS. FOR BEST RESULTS, USE NEW OR FRESHLY SHARPENED BLADES TO CUT THE DECORATIVE ALUMINUM COVERS.
4. CAREFULLY DEBUR AND CLEAN ANY SHARP EDGES ON THE DECORATIVE ALUMINUM COVERS AS NECESSARY.
5. MEASURE AND MARK CENTERLINE FOR ATTACHMENT FASTENERS ON RETAINER SECTIONS.
6. MEASURE AND MARK VERTICAL CENTERLINES FOR RETAINER ATTACHMENT FASTENERS ON THIS CENTERLINE. RETAINER FASTENERS SHOULD BE NO MORE THAN 32" ON CENTER AND WITHIN 3" OF THE END OF EACH RETAINER SEGMENT.
7. MEASURE AND MARK VERTICAL CENTERLINES FOR ATTACHMENT FASTENERS ON THE RAIL SYSTEM CENTERLINE ON WALL OR PARTITION.
8. DRILL FASTENER HOLES IN WALL OR PARTITION. FOR MOST DRYWALL APPLICATIONS WE RECOMMEND 1/4" BOLTS AND SIZE "BB" STRAP TYPE TOGGLER BRAND TOGGLES. FOR MOST MASONRY APPLICATIONS WE RECOMMEND 1/4" SCREWS AN NO. A-6 TOGGLER BRAND ALLIGATOR ANCHORS.
9. DRILL FASTENER HOLES IN RETAINER LENGTHS TO ALIGN WITH HOLES ON WALL OR PARTITION. MAKE HOLES AS SMALL AS POSSIBLE, ALLOWING FOR FASTENERS.
10. SECURE RETAINERS TO WALL OR PARTITION. IF SPLICES WERE NECESSARY, MAKE SURE ADJOINING SECTIONS ARE ALIGNED EXACTLY TO FACILITATE MOUNTING ALUMINUM COVERS.
11. INSTALL COVERS (OFFSETTING THE COVER JOINTS FROM THE WOOD RETAINER JOINTS IS RECOMMENDED FOR A MORE UNIFORM APPEARANCE). SLIDE THE TOP LIP INTO THE GROOVE IN THE TOP OF THE RETAINER, AND ROTATE DOWNWARD UNTIL THE COVER IS TIGHT ON THE RETAINER. SECURE THE COVER ON THE BOTTOM EDGE WITH SCREWS.
12. INSTALL END PLATES. HOLD END PLATE IN POSITION, TAKING CARE TO ALLOW EQUAL OVERLAP OF THE RETAINER TOP, BOTTOM, AND FRONT FACE OF COVER. MARK HOLES FOR ATTACHMENT SCREWS, AND DRILL PILOT HOLES FOR #10X2" STAINLESS STEEL OVAL HEAD SCREWS. ATTACH END PLATES.
13. WHEN COMPLETE, CLEAN SURFACES AS NECESSARY.

ASSEMBLY DRAWING

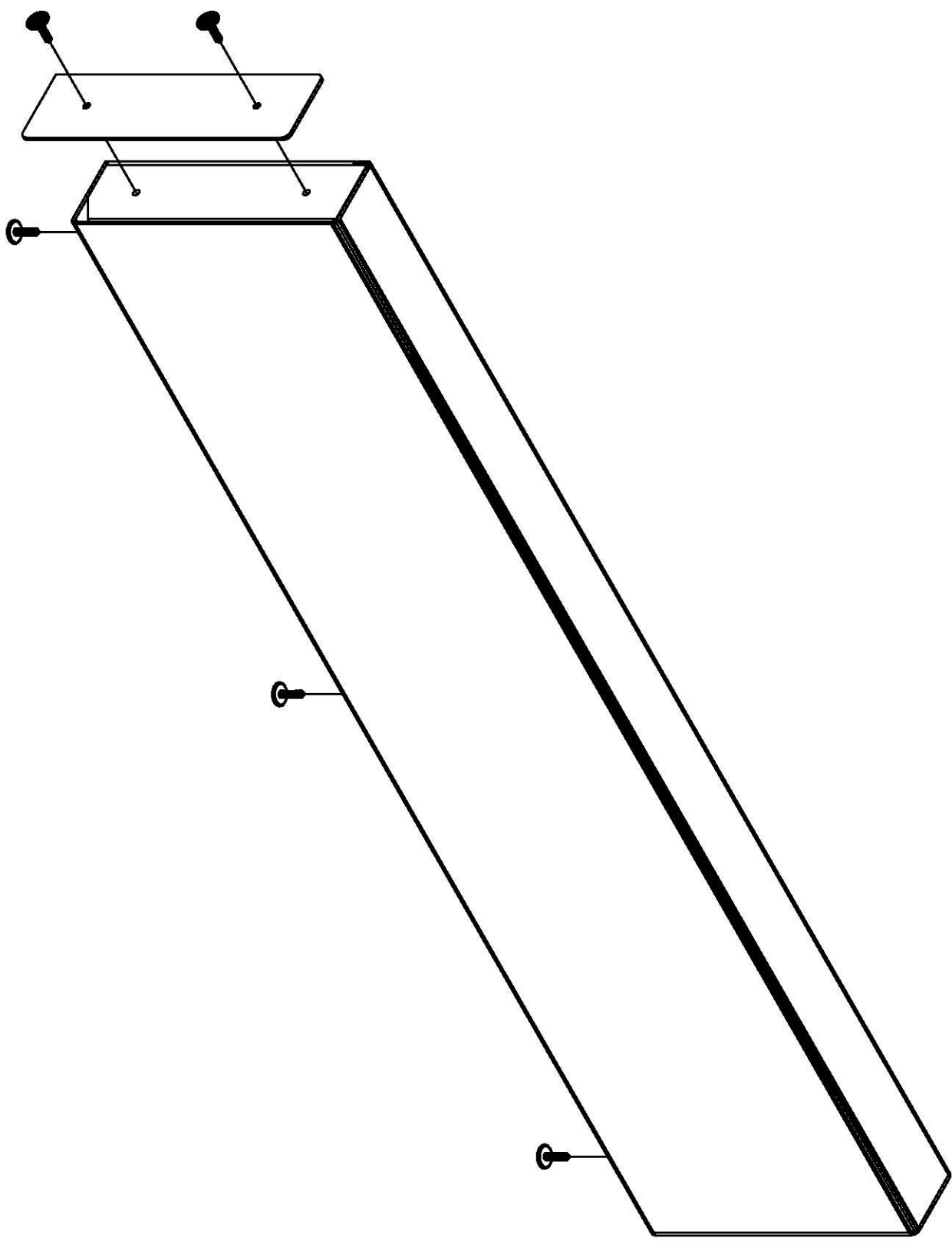

STANDARD PLAN DETAIL

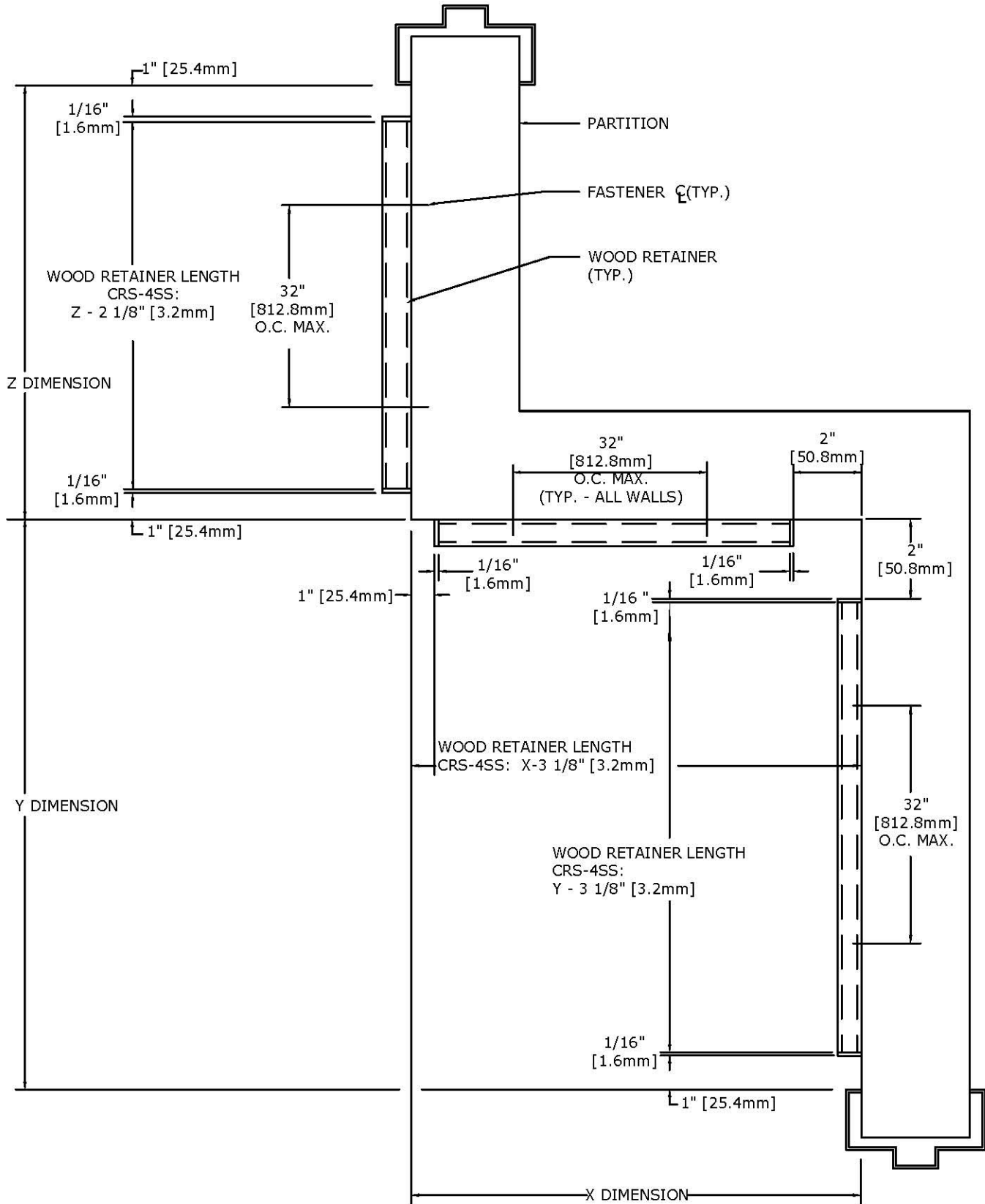

NOTE: Retainer fasteners should be no more than 32"(812.8mm) on center and within 3"(76.2mm) of the end of each retainer segment.